

Table Of Contents

2.Important Safety Instructions	20. Speed Dial Memory
3.Introduction	20. To Program or Edit a Speed Memory Location
4. Parts Check List	21. To Delete a Speed Memory Location
5. Handset and Handset Charger Layout	21. To Delete ALL Speed Memory Locations
6. Base Unit Layout	21. To Dial from Speed Memory
7.Getting Started	22.Advanced Operations
7. Setup	22. Caller ID
7. Connection of Phone and Power Lines	22. NOTES ABOUT CALLER ID & CALL WAITING CALLER ID
8. Installation of Battery Pack in Handset	22. Caller ID Display of Inbound Call
8. Charging of Handset Battery Pack	23. Reviewing Caller ID Memory
9. System Programming	23. Dialing from Caller ID Memory
10. Ringer ON/OFF	23. Storing Caller ID Records into Speed Dial Memory
10. Ringer Type	24. Deleting a Single Caller ID Record
10. Ringer Volume Control	24. Deleting all Caller ID Records
10. Handset and Base Unit Security Codes	25. Visual Message Waiting Indication
11. Handset ID	26. Transfer
12. Handset Name	26. Announced Transfer
13. Hold Reminder	26. Blind Transfer
13. Tone/Pulse	27. Conference
13. Flash Time	27. To Establish a 2 Handsets / 1 Outside Line Conference:
14. Home Area Code	27. To Establish a 1 Handset / 2 Outside Lines Conference:
14. Local Area Codes	
14. Line in Use Detection	28.Additional Information
15. Auto Pick Up	28. Headset Operation / Out of Range Indication
15. Handset Reset	29. Low Battery Warning / Spare Battery Charger
15. Base Reset	30. Maintenance
16. Do Not Disturb (DND)	31. In Case of Difficulty
16. Wall Mounting	33. Warranty
17.Basic Operations	35. Technical Specifications
17. Placing Calls	36. FCC and IC Regulations
17. Live Dialing	
17. Pre-Dialing	
18. Receiving Calls	
19. Mute	
19. Hold	
19. Intercom	
19. To Establish an Intercom Call	

Important Safety Instructions

When using your telephone equipment, basic safety precautions should always be followed to reduce the risk of fire, electric shock and injury, including the following:

1. Read and understand all instructions.
2. Follow all warnings and instructions marked on the product.
3. Unplug this product from the wall outlet before cleaning. Do not use liquid cleaners or aerosol cleaners. Use a damp cloth for cleaning.
4. Do not use this product near water (for example, near a bath tub, kitchen sink, or swimming pool).
5. Do not place this product on an unstable cart, stand, or table. The product may fall, causing serious damage to the product.
6. Slots and openings in the cabinet and the back or bottom are provided for ventilation. To protect it from overheating, these openings must not be blocked by placing the product on a bed, sofa, rug, or other similar surface. This product should never be placed near or over a radiator or heat register. This product should not be placed in a built-in installation where proper ventilation is not provided.
7. This product should be operated only from the type of power source indicated on the marking label. If you are not sure of the type of power supply to your home, consult your dealer or local power company.
8. Do not allow anything to rest on the power cord. Do not locate this product where the cord could be damaged by persons walking on it.
9. Never push objects of any kind into this product through cabinet slots as they may touch dangerous voltage points or short out parts that could result in a risk of fire or electric shock. Never spill liquid of any kind on the product.
10. To reduce the risk of electric shock, do not disassemble this product. Opening or removing cabinet parts other than specified access doors may expose you to dangerous voltages or other risks. Incorrect reassembly can cause electric shock when the appliance is subsequently used.
11. Do not overload wall outlets and extension cords as this can result in the risk of fire or electric shock.

Introduction

The VT 40-2421 / 40-2420 is an advanced 4-line cordless telephone system that operates in the 2.4GHz frequency range.

Your VT 40-2421 / 40-2420 is capable of supporting up to 12 Handsets. Four handsets (extensions) can be active at any given time.

Possible scenarios to have four handsets active at the same time:

- Four handsets (HS1, HS2, HS3, and HS4) on active calls, using all four lines (L1, L2, L3, and L4)
- Two handsets conferenced on an active call (HS1 + HS2 on L1) with two other handsets in an intercom call (HS3 + HS4 on intercom)
- Two handsets conferenced on an active call (HS1 + HS2 on L1) with two other handsets, each on an active call using different lines (HS3 on L2) and (HS4 on L3).

This manual is designed to familiarize you with the VT 40-2421 / 40-2420 cordless telephone system. We strongly recommend you read the manual before using your phone.

To order additional system Handsets (model# VT 40-2420), battery packs, or headsets, please call:

In the United States:

VTECH COMMUNICATIONS

1-800-595-9511

In Canada:

VTECH ELECTRONICS

1-800-267-7311

Parts Check List

1. Base Unit and power adapter
2. Handset
3. Handset Charger and power adapter
4. Handset battery pack
5. Wall Mount Bracket
6. Telephone line cord (x2)
7. Belt clip

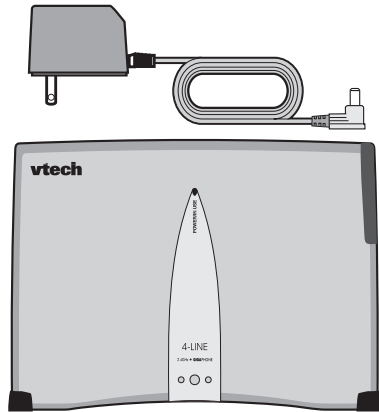

Base Unit and Power Adapter

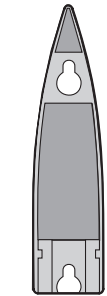

Wall Mounting Bracket



Handset



Handset Battery Pack

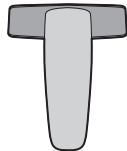

Belt Clip



Telephone Line Cord (x2)

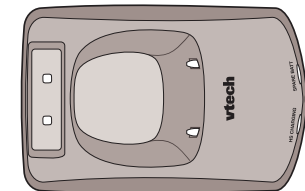
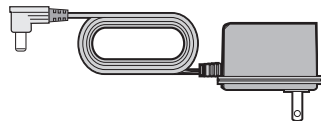

Handset Charger and Power Adapter

The Handset and Handset Charger Layout

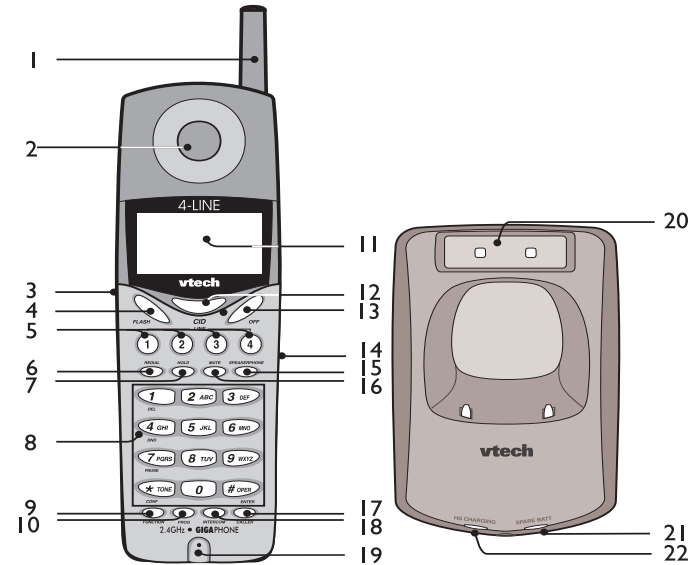

HANDSET

CHARGER

1. Antenna
2. Earpiece
3. Volume/Scroll Keys
4. FLASH
5. Line 1,2,3,4
6. REDIAL
7. HOLD
8. Dialing Keys (0-9)
9. FUNCTION
10. PROG
11. LCD Display
12. CID
13. OFF
14. Headset Jack (2.5mm)
15. SPEAKERPHONE
16. MUTE
17. CALLER
18. INTERCOM
19. Microphone
20. Spare Battery Charging Slot
21. SPARE BATT LED
22. HS CHARGING LED

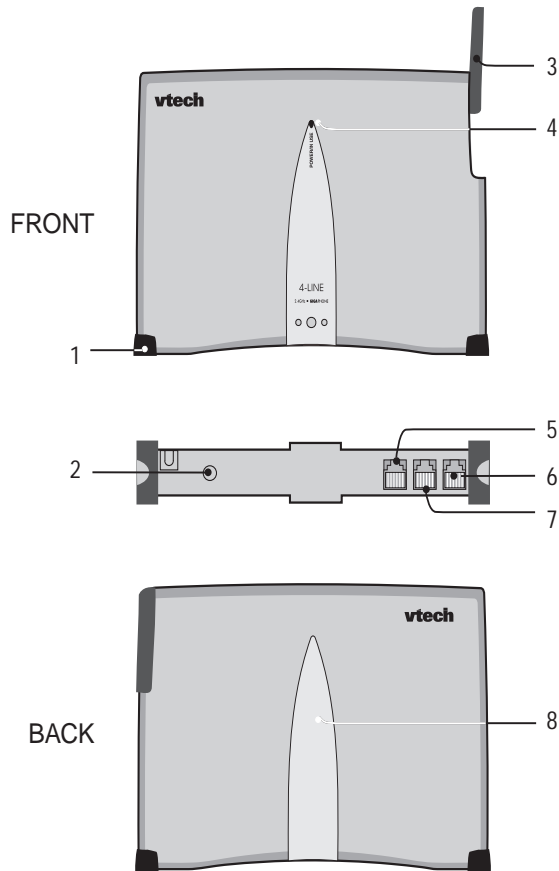

- | | |
|----------------------------|-------------------------|
| 1. Rubber Foot | 5. L3/L4 Telephone Jack |
| 2. DC Connector | 6. AUX Dataport Jack |
| 3. Antenna | 7. L1/L2 Telephone Jack |
| 4. Power/ In use Indicator | 8. Wall Mount Cover |

Connection of Phone and Power Lines

•VT 40-2421 setup

1. Plug the AC power adapter into an electrical outlet, and the DC connector into the back of the base unit.
2. There are three modular telephone connections on the base unit L1/L2, L3/L4 and an AUX dataport to allow direct connection of a fax or modem. The dataport is linked to the L2 connection only.
3. Plug one end of the telephone line cord(s) into the jack(s) on the back of the base unit. Plug the other end of this cord into the wall jack.
4. Plug the AC power adapter into an electrical outlet, and the DC connector into the back of the handset charger.
5. Install handset battery and allow handset to charge for at least 15 hours initially.

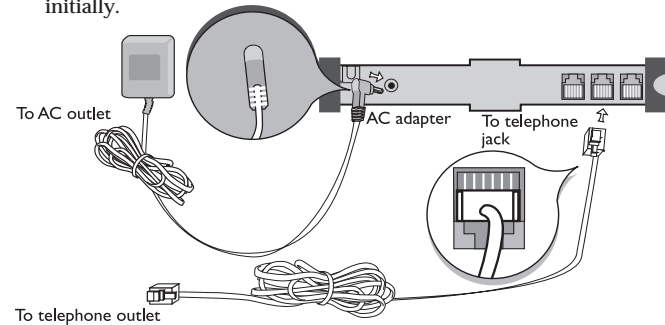

•VT 40-2420 setup

1. Plug the AC power adapter into an electrical outlet, and the DC connector into the back of the handset charger.
2. Install handset battery and allow handset to charge for at least 15 hours initially.

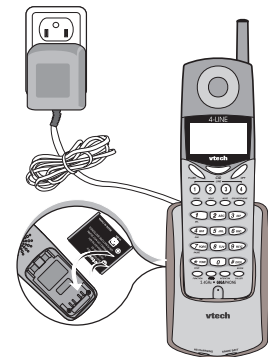

Setup

Installation of Battery Pack in Handset

Follow the steps below:

1. Remove the battery cover by pressing on the indent and sliding downward.
2. Place the new battery pack in the handset with the metal contacts aligned with the charge contacts in the battery compartment.
3. Replace the battery cover by sliding it upwards.
4. If the new battery pack is not already charged, place the handset in the handset charger, and allow it to charge for 15 hours. After initial charge, a maintenance charge of 8 hours should be sufficient.

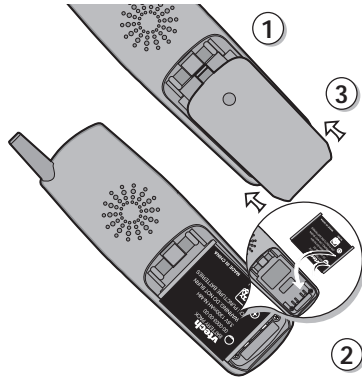

The original Handset that is shipped with your VT 40-2421 system will be automatically registered to the Base. This Handset is **HANDSET 1**.

As you register additional Handsets to the system, you should assign extension numbers in the following order: **HANDSET 2, HANDSET 3, HANDSET 4, HANDSET 5, HANDSET 6, HANDSET 7, HANDSET 8, HANDSET 9, HANDSET 10, HANDSET 11**, and finally **HANDSET 12**. See **Handset ID** and **Handset Name**.

Charging of Handset Battery Pack

The Handset of your VT 40-2421 cordless telephone is powered by a rechargeable battery pack. It charges automatically whenever the Handset is in the Charger.

You should charge the battery pack for 15 hours when you first receive your phone. You may also need to charge the battery under the following conditions:

- The low battery message is displayed:
- The handset seems completely dead, the LCD is completely clear and does not activate when you press the keys.

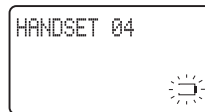

IMPORTANT:

1. Do not dispose of a battery pack in a fire, the cell may explode.
2. Do not open or mutilate the battery pack. Toxic substances may be released, causing harm to eyes or skin.
3. Exercise care in handling battery packs in order to prevent an accidental short of the charge contacts, potentially causing the battery pack to overheat.
4. Do not dispose of this battery pack into household garbage.

Setup

System Programming

The VT 40-2421 / 40-2420 is controlled by a sophisticated menu structure. To access the program mode, start with the handset in idle (off) mode and then press the **PROG** key. Use the (▲/▼) volume keys to navigate through the menu, and the # key to make selections. At any time, you can press the **OFF** key to exit without saving changes. If you do not press a key for 30 seconds, the system will automatically exit **program** and return to idle mode.

Flow chart of program mode: If the handset is in idle (off) mode, press **PROG**

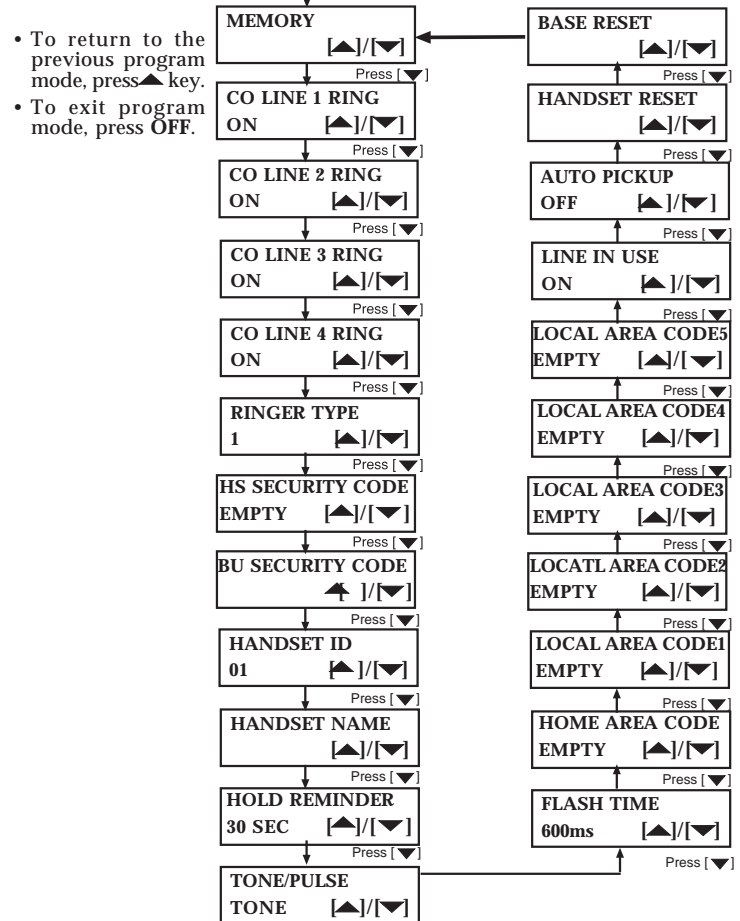

Setup

Ringer ON/OFF

- Access **program** mode
- Press the (▼) key until you see **CO LINE 1 RING**
- Press the # key to change settings. The cursor will blink to the right of the current setting
- Use the (▼/▲) volume keys to select either **ON** or **OFF**.
- Press the # key to confirm choice.
- **PROGRAMMING SUCCESSFUL!** is displayed.
- Repeat the above steps to set ringers for **LINE 2**, **LINE 3** and **LINE 4**

```
MEMORY
      [▲]/[▼]
```

```
CO LINE 1 RING
ON      [▲]/[▼]
```

```
PROGRAMMING
SUCCESSFUL!
```

Ringer Type

- Access **program** mode
- Press the (▼) key until you see **RINGER TYPE**
- Press the # key to change settings. The cursor will blink to the right of the current ringer setting
- Use the (▼/▲) volume keys to sample the four ringer types
- Press the # key to confirm choice
- **PROGRAMMING SUCCESSFUL!** is displayed, and the selected ringer type will be played once.

```
RINGER TYPE
1      [▲]/[▼]
```

Ringer Volume Control

- From the idle (off) mode press the (▼/▲) volume keys to select volume level **LOW / MID / HIGH**

```
HANDSET 04
RINGER: MID
```

Handset and Base Unit Security Codes

The VT 40-2421 is an advanced telephone system, which uses a unique 6-digit security code for operation. The VT 40-2421 Handset and Base unit are factory programmed with a default security code, which allows you use the system after charging.

NOTE: When using multiple Handsets, you must assign a 6-digit system security code (shared by all Handsets and Base Unit), and each Handset must be assigned its own unique HANDSET ID (extension) number.

Assigning the Handset Security Code and Loading into the Base Unit

- Disconnect the AC power to the base unit.

Setup

- Made sure that only **HANDSET 01** has a battery pack installed. All other Handsets need to have their battery packs removed during this process.
- Access **program** mode
- Press the (▼) key until you see **HS SECURITY CODE**
- Press the # key to change settings. You will be prompted to **PLS ENTER CODE**, waiting for you to input a 6-digit security code. This security code is selected by you, so please choose a security code that you will remember. Also, record the **HS SECURITY CODE** in the space below for future reference.
SECURITY CODE: _____
- Use the number keys to enter the 6 digit **HS SECURITY CODE** (i.e. 123456, 223455, 000005, etc.)
- Press the # key to confirm choice
- **PROGRAMMING SUCCESSFUL!** is displayed.

```
HS SECURITY CODE
      [▲]/[▼]
```

```
PLS ENTER CODE
█
```

You now need to load the **HS SECURITY CODE** into the Base Unit, using **HANDSET 01**. Please follow these steps:

- The Base Unit power should still be disconnected.
- Access **program** mode
- Press the (▼) key until you see **BS SECURITY CODE**
- Reconnect the Base Unit power. **Once the power is connected, you have only 10 seconds to complete the next step.**
- With **BS SECURITY CODE** displayed on **HANDSET 01**, press the # key. The **HS SECURITY CODE** has now been loaded into the Base Unit.
- **PROGRAMMING SUCCESSFUL!** is displayed.
- If you fail in loading the **HS SECURITY CODE** into the Base Unit, **ERROR! PLS REGISTER AGAIN!** is displayed, you have to repeat the above 6 steps to load into the Base Unit until **PROGRAMMING SUCCESSFUL!** is displayed.

```
BS SECURITY CODE
      [▲]/[▼]
```

```
ERROR! PLS
REGISTER AGAIN!
```

Handset ID

The VT 40-2421 system supports up to 12 extension handsets. In order to use the multiple handset capability of this product, **you must first assign a 6-digit security code**. Please refer to **Handset and Base Unit Security Codes** before proceeding with Handset ID.

Setup

When multiple handsets are added to the **VT 40-2421** system, you must first assign a unique ID (extension number) for each Handset, and then enter the system security code. Valid ID numbers are 01, 02, 03, 04, 05, 06, 07, 08, 09, 10, 11 and 12.

CAUTION: Be careful not to assign the same Handset ID number to more than one Handset.

• If you have not already selected a system security code, follow the steps in **Handset and Base Security Codes** above. Then do the following:

- Access **program** mode
- Press the (▼) key until you see **HANDSET ID**
- Press the # key to change settings. The cursor will blink to the right of the current **HANDSET ID** setting
- You will be prompted to **PLS ENTER ID NO**
- Use the number keys to enter the two digit ID code (i.e. 01, 02...12)
- Press the # key to confirm choice
- **PROGRAMMING SUCCESSFUL!** is displayed.
- Press the (▼) key until you see **HS SECURITY CODES**
- Press the # key. You will be prompted to **PLS ENTER CODE**, waiting for you to input the 6 digit security code you previously selected.
- Use the number keys to enter the same 6 digit **HS SECURITY CODE** for this **VT40-2421** system.
- Press the # key to confirm choice
- **PROGRAMMING SUCCESSFUL!** is displayed.

```
HANDSET ID
01      [▲]/[▼]
```

```
PLS ENTER ID NO.
█
```

```
HS SECURITY CODE
        [▲]/[▼]
```

```
HANDSET NAME
EMPTY   [▲]/[▼]
```

```
PLS ENTER NAME
█
```

```
PLS ENTER NAME
Thomas █
```

```
PROGRAMMING
SUCCESSFUL!
```

Handset Name

If you want to assign a name for a handset, follow the steps below:

- Access **program** mode
- Press the (▼) key until you see **HANDSET NAME**
- Press the # key to change settings. The cursor will blink to the right of the current **HANDSET NAME** setting.
- You will be prompted to **PLS ENTER NAME**
- Use the digit keys to 'spell' the name. Names can be up to 16 characters. To enter a specific set of characters, see **Speed Dial Memory: To Program or Edit a Speed Memory Location**.
- Press the # key to confirm the name.
- **PROGRAMMING SUCCESSFUL!** is displayed.

Setup

Hold Reminder

The **VT 40-2421** system has an option to activate a hold reminder, which plays a brief tone to alert you that a call is on hold. Each handset is programmed independently. All handsets linked to the system will be alerted at the selected interval (15sec, 30sec, 45sec, or 60sec) unless **OFF** is selected.

- Access **program** mode
- Press the (▼) key until you see **HOLD REMINDER**
- Press the # key to change settings. The cursor will blink to the right of the current ringer setting.
- Use the (▼/▲) volume keys to cycle through the five options (15sec, 30sec, 45sec, 60sec, OFF).
- Press the # key to confirm choice
- **PROGRAMMING SUCCESSFUL!** is displayed.

```
HOLD REMINDER
30SEC   [▲]/[▼]
```

Tone/Pulse

If you have touch tone service, do not change the setting of this mode. If you have rotary(Pulse) service, you have to access **TONE/PULSE** mode and set to **PULSE**.

- Access **program** mode
- Press the (▼) key until you see **TONE/PULSE**
- Press the # key to change settings. The cursor will blink to the right of the current ringer setting.
- Use the (▼/▲) volume keys to choose **TONE** or **PULSE**
- Press the # key to confirm choice
- **PROGRAMMING SUCCESSFUL!** is displayed.

```
TONE/PULSE
TONE    [▲]/[▼]
```

Flash Time

This function is commonly used with service such as Call Waiting. The default setting for flash time is 600ms. It is unlikely that you will need to change this setting, however, if required you can adjust the flash time from 100ms to 900ms in 100ms intervals.

- Access **program** mode
- Press the (▼) key until you see **FLASH TIME**
- Press the # key to change settings. The cursor will blink to the right of the current setting.
- Use the (▼/▲) volume keys to choose flash setting (100ms, 200ms...900ms)
- Press the # key to confirm choice
- **PROGRAMMING SUCCESSFUL!** is displayed.

```
FLASH TIME
600ms   [▲]/[▼]
```

Note: Please consult your local telephone service provider when you want to change the Flash Time.

Setup

Home Area Code

If you live in an area where you dial calls within your own area code by dialing 7 digits (no area code), follow these steps:

- Access **program** mode
- Press the (▼) key until you see **HOME AREA CODE**
- Press the # key to change settings. The cursor will blink to the right of the current setting.
- Use the number keys to enter your home area code
- Press the # key to confirm choice
- **PROGRAMMING SUCCESSFUL!** is displayed.

```
HOME AREA CODE
EMPTY      [▲]/[▼]
```

Local Area Codes

You can program up to five local area codes. Please note that the **HOME AREA CODE** should be empty if you are using the local area programming. If you live in an area where all local calls require 10 digits (area code plus phone number, without dialing "1" first) follow these steps:

- Access **program** mode
- Press the (▼) key until you see **LOCAL AREA CODE1**
- Press the # key to change settings. The cursor will blink to the right of the current setting.
- Use the number keys to enter your local area code
- Press the # key to confirm choice
- **PROGRAMMING SUCCESSFUL!** is displayed.
- Repeat the above steps for LOCAL AREA CODE2, CODE3, CODE4 and CODE5

```
LOCAL AREA CODE1
EMPTY      [▲]/[▼]
```

```
LOCAL AREA CODE2
EMPTY      [▲]/[▼]
```

Line in Use Detection

There is a **LINE IN USE** indication when another telephone on the same line (parallel extension) is in use.

- Access **program** mode
- Press the (▼) key until you see **LINE IN USE**
- Press the # key to change settings. The cursor will blink to the right of the current setting.
- Use the (▼ /▲) volume keys to choose **ON** or **OFF**
- Press the # key to confirm choice
- **PROGRAMMING SUCCESSFUL!** is displayed.

```
LINE IN USE
ON          [▲]/[▼]
```

```
HANDSET 01
          ID
```

Setup

Auto Pick Up

Select this option and set to ON if you want the handset to automatically answer calls when the handset is lifted from the cradle (without having to press **LINE** or **SPEAKERPHONE**).

- Access **program** mode
- Press the (▼) key until you see **AUTO PICKUP**
- Press the # key to change settings. The cursor will blink to the right of the current setting.
- Use the (▼ /▲) volume keys to choose **ON** or **OFF**
- Press the # key to confirm choice
- **PROGRAMMING SUCCESSFUL!** is displayed.

```
AUTO PICKUP
OFF         [▲]/[▼]
```

Handset Reset

Select this option to reset a single handset to factory default settings.

NOTE: After selecting this option, you will need to re-assign the Handset ID and re-load the system security code.

- Access **program** mode
- Press the (▼) key until you see **HANDSET RESET**
- Press the # key to change settings
- You will be prompted to **RESET YES?**
- To exit without resetting press **OFF** key
- Press the # key to confirm choice
- **PROGRAMMING SUCCESSFUL!** is displayed.

```
HANDSET RESET
            [▲]/[▼]
```

```
RESET YES?
```

Base Reset

Select this option to reset base settings to factory default.

NOTE: After selecting this option, you will need to re-program the system security code. You will also need to re-assign a unique Handset ID (extension) number for each handset, and then re-load the 6 digit system security code into ALL SYSTEM HANDSETS.

- Access **program** mode
- Press the (▼) key until you see **BASE RESET**
- Press the # key to change settings
- You will be prompted to **RESET YES?**
- To exit without resetting press **OFF** key
- Press the # key to confirm choice
- **PROGRAMMING SUCCESSFUL!** is displayed.

```
BASE RESET
            [▲]/[▼]
```

```
RESET YES?
```

Setup

Do Not Disturb (DND)

If you do not want a particular handset to receive calls, activate the DND function by doing the following:

- Press **FUNCTION** key followed by the **4(DND)** key.
- The handset will display **DO NOT DISTURB!**
- To cancel the DND press **FUNCTION** followed by the **4(DND)** key again.

Note: When DND is enabled, you will not be able to pre-dial numbers.

```
(1)DEL (4)DND
(2)PAUSE (*)CONF
```

```
HANDSET 04
DO NOT DISTURB!
```

Wall Mounting

The Wall Mount bracket is designed for use on standard Wall Mount plates only.

- Remove the wall mount cover at the back of the Base Unit
- Line up the tabs on the wall mount bracket with the holes at the back of the Base Unit. Snap the wall mount bracket firmly in place.
- Mount the Base Unit on the wall. Position the Base Unit so the mounting stubs will fit into the holes on the wall mount bracket. Slide Base Unit down on the mounting stubs until it locks into place.

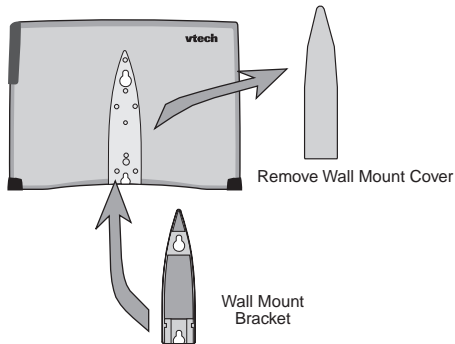

Placing Calls

Live Dialing

- Press the desired **LINE** key or **SPK.PHONE** (for handsfree on next available line). Listen for dial tone.
- Enter the number you wish to dial
- To end a call press **OFF** or place handset in charger cradle



```
LINE1 00:03
```

```
LINE1 SPKR 00:05
```

Pre-Dialing

- Enter the number you wish to dial on the display.
- Press the desired **LINE** key or **SPK.PHONE** (for handsfree on next available line).
- To end a call press **OFF** or place handset in charger cradle

Receiving Calls

- When you have an incoming call, the line and  icon will appear in the display above the corresponding **LINE** key. For example, if there is a call on **LINE 2**, the line 2 and  icon above **LINE 2** will be illuminated.
 - Also, if you have Caller ID service, the display will show **L1**, **L2**, **L3** or **L4** to the left of the Caller ID number information.
 - To answer an incoming call from an **IDLE** handset, do either of the following:
 - Press the appropriate **LINE** key
 - Press any key to answer the ringing line
 - Press **SPK.PHONE** (for handsfree on ringing line).
 - To answer an incoming call from an **ACTIVE** handset (on another call)
 - Press **OFF** to terminate the current call.
Or,
 - Place the current call on hold by pressing **HOLD**.
- Then do either of the following:
- Press the appropriate **LINE** key
 - Press any key to answer the ringing line
 - Press **SPK.PHONE** (for handsfree on ringing line).

NOTE: If you have **AUTO PICKUP** set to **ON**, a ringing handset will automatically answer the first ringing line, when lifted from the charge cradle. See **Auto Pick up Line Function**.

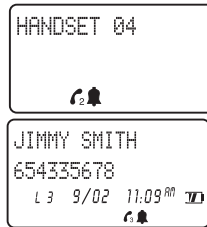

Mute / Hold / Intercom

Mute

During an active call, press the **MUTE** key to temporarily disable the handset microphone.

MUTE! Will be displayed.

Press the **MUTE** key again to resume normal two way conversation.

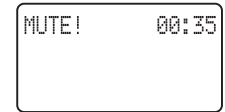

Hold

- To place an active call on hold, press the **HOLD** key.
- While a call is on hold the handset will display **TRANSFER TO/HOLD** and the corresponding line icon will flash.
- If you have **HOLD REMINDER** enabled, you will hear an alert tone at the specified interval (15sec, 30sec, 45sec, or 60sec).
- Once a call is on hold, any handset can then access the call by pressing the corresponding line key.

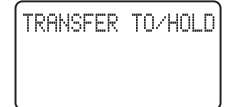

Note: If a call is placed on hold for more than 3 minutes, all handsets will receive a Recall Ring tone that serves as a reminder that a call remains on hold. Also, if a call is left on hold for more than 5 minutes, the VT 40-2421 system will automatically disconnect the line.

Intercom

To establish an intercom call

- Press the **INTERCOM** key, followed by the handset number (01..12).
- Once the other handset answers, the handset will display **TALKING!**
- To end the intercom call, either handset can press **OFF**.

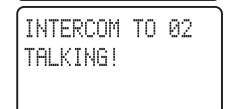
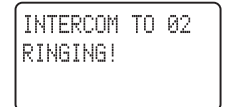
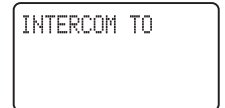

Speed Dial Memory

Each handset in the VT 40-2421 / 40-2420 system can store up to 20 names and numbers in a private speed dial memory. This is important to note, as each handset must be programmed separately.

To Program or Edit a Speed Memory Location

- Access **program** mode
- Press # to select **SPEED MEMORY**
- Use the (▼/▲) volume keys to scroll to a desired memory location (01...20)
- Press # select the Speed Memory location
- You will be prompted to enter **NAME?**
- Use the digit keys to 'spell' the name. Names can be up to 16 characters. Use (▼/▲) volume keys move left or right in the name field. Characters and symbols for name entry are located on the following number keys:

Key	Characters
1	SPACE - ' & . () @ 1
2	A, B, C, a, b, c, 2
3	D, E, F, d, e, f, 3
4	G, H, I, g, h, i, 4
5	J, K, L, j, k, l, 5
6	M, N, O, m, n, o, 6
7	P, Q, R, S, p, q, r, s, 7
8	T, U, V, t, u, v, 8
9	W, X, Y, Z, w, x, y, z, 9
0	0
*	*
#	#

- Press the # key to confirm the name.
- Using the digit keys enter **NUMBER** when prompted
- To enter a pause, press the **FUNCTION** key followed by the 7 (**PAUSE**) key

```
SPEED MEMORY
      [▲]/[▼]
```

```
EMPTY
                        M01
```

```
NAME?
```

```
123
NUMBER?
```

Speed Dial Memory

- Press the # key to confirm number
- **PROGRAMMING SUCCESSFUL!** is displayed

To Delete a Speed Memory Location

- Access **program** mode
- Press # to select **SPEED MEMORY**
- Use the (▼/▲) volume keys to scroll to a desired memory location (01...20)
- Press the **FUNCTION** key followed by the 1 (**DEL**) key to delete
- Press # to confirm deletion
- **PROGRAMMING SUCCESSFUL!** is displayed; or press **OFF** key to exit without deleting

```
JOHN SMITH
DELETE?           M01
```

To Delete ALL Speed Memory Locations

- Access **program** mode
- Press # to select **SPEED MEMORY**
- Press the **FUNCTION** key followed by the 1 (**DEL**) key to delete
- Press # to confirm deletion
- **PROGRAMMING SUCCESSFUL!** is displayed; or press **OFF** key to exit without deleting

```
SPEED MEMORY
DELETE ALL?
```

To Dial from Speed Memory

- Access **program** mode
- Press # to select **SPEED MEMORY**
- Use the (▼/▲) volume keys to scroll to a desired memory location (01...20)
- Press the desired **LINE** key or **SPK.PHONE** (for handsfree on next available line)
- To end a call press **OFF** key or place handset in charger cradle

Caller ID

The **VT 40-2421** system is capable of displaying the name and/or number of the party calling before you answer the phone (**Caller ID**). It is also capable of displaying Caller ID information in conjunction with a Call Waiting alert signal (**Call Waiting Caller ID**). With Call Waiting Caller ID, the Caller ID data is displayed so you can decide whether to answer the incoming call, or continue with your current conversation. The **VT 40-2421** system stores the last 50 calls with name, number and time/date of each call received.

NOTES ABOUT CALLER ID & CALL WAITING CALLER ID

These are subscription services, provided by most regional telephone service providers. You must subscribe to these services to get the benefits of these features. If you do not subscribe to Caller ID services, you can still use your **VT 40-2421** system and the other features it offers. Due to regional incompatibilities, Caller ID information may not be available for every call you receive. In addition, the calling party may intentionally block their name and phone number from being sent.

Some of the special Caller ID messages you may receive include:

NO CALLER INFO or **OUT OF AREA**: May be displayed if either the name and/or number information is not received by the **VT 40-2421** system.

PRIVATE: May be displayed if the calling party has intentionally blocked their name and phone number from being sent.

If more than one line is ringing at the same time, you can review the incoming Caller ID information by pressing the **CALLER** key. Each press of the **CALLER** key will switch between the Caller ID information from currently ringing lines, and the handset idle display. To answer a particular line, simply press the corresponding **LINE** key.

Caller ID display of inbound call

As a call is received on the **VT 40-2421** system, the Caller ID information is displayed in the following format:

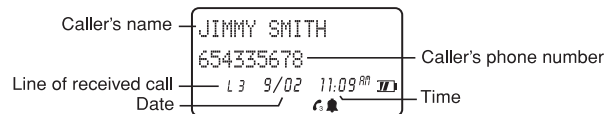

Caller ID

Reviewing Caller ID Memory

- Press the **CID** key
- The display will show a counter of calls stored Caller ID memory.
 - * **ALL CID**: Represents the total number of Caller ID records stored
 - * **NEW CID**: Represents the total number of calls that have been received since you last reviewed the Caller ID memory.
- Use the (▼ / ▲) volume keys to scroll through Caller ID memory.
- Pressing the ▲ arrow will start with the most recent call received.
- Pressing the ▼ arrow will start with the oldest call received.
- When you reach the end of the list, you can 'wrap around' to the beginning by pressing the (▼ / ▲) key again.

ALL CID:XX
NEW CID:XX

Dialing from Caller ID Memory

- Press the **CID** key
- Use the (▼ / ▲) volume keys to scroll through Caller ID memory.
- Press an available line key (**L1**, **L2**, **L3**, **L4**) to automatically dial the displayed number.
- You can also press the **SPK.PHONE** key to activate the handset speakerphone on the next available line.
- Press **OFF** key to end the call.

Storing Caller ID Records into Speed Dial Memory

- Press the **CID** key
- Use the (▼ / ▲) volume keys to locate the Caller ID record to be stored into Speed Dial memory.

ANDREW SMITH
L2: 12345678
03 9/10 10:00 AM

Caller ID

- Press the **PROG** key
- Press **#** to enter **SPEED MEMORY**.
- Use the (**▼** / **▲**) volume keys to locate the memory location (01..20) where you wish to store the Caller ID record
- Press the **CID** key. The Caller ID record will be displayed along with the memory location number.
- Press **#** to proceed.
- Review the displayed name. Make changes if necessary, and then press the **#** key.
- Review the displayed number. Make changes if necessary, and then press the **#** key
- **PROGRAMMING SUCCESSFUL!** is displayed.

```
ANDREW SMITH
12345678      M02
```

```
ANDREW SMITH
NAME?
```

```
12345678
NUMBER?
```

Deleting a Single Caller ID Record

- Press the **CID** key
- Use the (**▼** / **▲**) volume keys to locate the Caller ID record to be deleted.
- Press **FUNCTION** followed by the **1 (DEL)** key to delete
- The name of the selected memory location will be displayed.
- Press **#** to confirm deletion
- **DELETED!** is displayed; or press **OFF** to exit without deleting

```
ANDREW SMITH
DELETE?
```

```
ALL CID: 12
NEW CID: 01
```

Deleting All Caller ID Records

- Press the **CID** key
- Press **FUNCTION** followed by the **1 (DEL)** key to delete all Caller ID records.
- **DELETE ALL CID?** will be displayed.
- Press **#** to confirm deletion

```
DELETE ALL CID?
```

```
ALL CID: 00
NEW CID: 00
```

Visual Message Waiting Indication

The **VT 40-2421** is compatible with optional voicemail service provided by some local telephone companies. If you subscribe to this service, and you have new, unplayed messages in your voicemail, a Visual Message Waiting Indicator (VMWI) signal is transmitted by your local telephone company.

```
MESSAGE WAITING
ON LINE 1,2,3,4
```

The **VT 40-2421** detects a VMWI signal and activates a the Message Waiting indicator on the Handset(s).

```
MESSAGE WAITING
ON LINE 3
```

After you check your messages, the Message Waiting indicator will automatically turn off.

Please note that whenever new, unplayed messages are stored in your voicemail, the local Telephone Company will continue to send a VMWI signal.

If after reviewing unplayed messages, the **MESSAGE WAITING** display remains, you can manually delete the indicator as follows:

- Start from an idle mode with **MESSAGE WAITING** actively being displayed.
- Press **FUNCTION** followed by **1(DEL)** to delete
- **DEL MSG DISPLAY?** is displayed.

```
DEL MSG DISPLAY?
[1,2,3,4,ALL(0)]
```

* Press **1** to delete the **MESSAGE WAITING** indicator for LINE 1

```
MESSAGE WAITING
ON LINE 2,3,4
```

* Press **2** to delete the **MESSAGE WAITING** indicator for LINE 2

* Press **3** to delete the **MESSAGE WAITING** indicator for LINE 3

```
MESSAGE WAITING
ON LINE 1,2, 4
```

* Press **4** to delete the **MESSAGE WAITING** indicator for LINE 4

* Press **0** to delete the **MESSAGE WAITING** indicator for ALL lines

Transfer

Announced Transfer

- While on an active call, press the **INTERCOM** key followed by the handset number you wish to call. The active call will be automatically placed on hold.
- When the other handset answers, simply announce there is a call for them on a particular line.
- As soon as the other handset answers the held line, the intercom will be automatically terminated.
- You can also press **OFF** to end the intercom at any time.

Blind Transfer

- Place an active call on hold, by pressing the **HOLD** key.
- The handset will display **TRANSFER TO/HOLD**.
- Enter the handset number you wish to transfer the call to (01..12)
- The call will be automatically transferred to the selected handset

```
TRANSFER TO 02
```

Conference

To Establish a 2 Handsets / 1 Outside Line Conference:

- Place an active call on hold, by pressing the **HOLD** key.
- Place an intercom call to another handset by pressing the **INTERCOM** key, followed by the handset number (01..12).
- Once the other handset answers, press the **FUNCTION** key followed by the ***(CONF)** key to establish the conference call between both handsets and the outside line.
- Either handset can then exit the conference by pressing **OFF**.

```
TRANSFER TO/HOLD
```



```
INTERCOM TO 02  
TALKING!
```



```
(1)DEL (4)DND  
(2)PAULSE(*)CONF
```



```
LINE3 01:35
```



To Establish a 1 Handset / 2 Outside Lines Conference:



(for example HS1 on L1 and L3)

- Place an active call on hold (L1), by pressing the **HOLD** key.
- Answer or place another call (L3).
- Press the **FUNCTION** key followed by the ***(CONF)** key to establish the conference call between the handset and both outside lines.
- The handset will display **L1 + L3**.
- To end the conference for both lines press **OFF**.
- To continue the call for only one line, and to end the call on the other line, simply press the **LINE** key of the call you wish to continue. The other line will be automatically terminated.

```
LINE1 01:48  
654335677
```





```
LINE3 01:15  
12345678
```

```
(1)DEL (4)DND  
(2)PAUSE (*)CONF
```



```
L1+L3 01:35  
12345678
```

Headset Operation / Out of Range Indication

Headset Operation

Your VT 40-2421 cordless telephone system is equipped with 2.5mm Headset Jacks on each handset for use with an optional accessory Headset for handsfree operation. If you choose to use the Headset option, you must obtain an optional accessory Headset, which is compatible with the VT 40-2421/40-2420.



To purchase a Headset, please call:

In the United States:

VTECH COMMUNICATIONS

1-800-595-9511

In Canada:

VTECH ELECTRONICS

1-800-267-7311

Once you have a compatible 2.5mm Headset, locate the Headset Jack on the VT 40-2421 / 40-2420 Handset. Connect the plug on the Headset cord to the jack on the cordless Handset. The plug should fit securely. Do not force the connection.

NOTE :

Whenever a compatible Headset is connected to the cordless Handset, the microphone on the Handset will be muted. This is done to limit the effect of background noise.

Out of Range Indication

The handset will display **OUT OF RANGE** along with an audible warning if the handset is too far from the base unit. You have to move closer to the base unit to ensure uninterrupted service.

If you are on an active call when the **OUT OF RANGE** alert appears, you must correct the problem within 20 seconds, or the call will be automatically held.

Low Battery Warning/Spare Battery Charger

Low Battery Warning

A warning indicator appears when the handset battery becomes weak. If you are on a call when a battery low alert appears, you will hear a double beep every 10 seconds, indicating that you should replace the drained battery pack immediately.

Battery Indicator

A battery icon located in the lower right corner of the Handset display provides a visual indication of the current battery level. As the battery is drained, the icon will transition from full to empty.

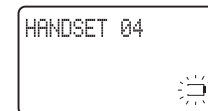

Spare Battery Charger

The spare battery charger slot is located at the back of the handset charger. It is recommended that a spare battery should be fully charged in the spare battery charger for 15 hours before the initial use. The spare battery pack can be used to replace a drained handset battery, ensuring uninterrupted

NOTE :

When using the VT 40-2421/40-2420 during low battery mode, audio quality may be compromised due to reduced power availability.

- Place a battery pack in the spare battery charging slot with the charge contacts facing down. The spare battery takes 12 hours to fully charge a drained battery.
- The spare battery charger takes 15 hours to fully charge a drained battery.

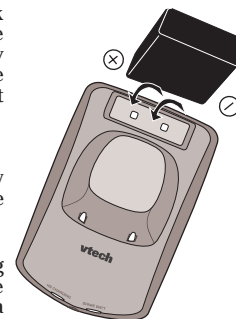

To order additional system Handsets (model# VT40-2420), battery packs, or headsets, please call:

In the United States:

VTECH COMMUNICATIONS

1-800-595-9511

In Canada:

VTECH ELECTRONICS

1-800-267-7311

Maintenance

Taking Care Of Your Telephone

Your VT 40-2421 cordless telephone system contains sophisticated electronic parts, so it must be treated with care.

Avoid rough treatment

Place the Handset down gently. Save the original packing materials to protect your telephone if you ever need to ship it.

Avoid water

Your telephone can be damaged if it gets wet. Do not use the Handset outdoors in the rain, or handle it with wet hands. Do not install your Base Unit near a sink, bathtub or shower.

Electrical storms

Electrical storms can sometimes cause power surges harmful to electronic equipment. For your own safety, use caution when using electric appliances during storms.

Cleaning your telephone

Your telephone has a durable plastic casing that should retain its luster for many years. Clean it only with a soft cloth slightly dampened with water or a mild soap. Do not use excess water or cleaning solvents of any kind.

Remember that electrical appliances can cause serious injury if used when you are wet or standing in water. If your Base Unit should fall into water, **DO NOT RETRIEVE IT UNTIL YOU UNPLUG THE POWER CORD AND TELEPHONE LINE CORDS FROM THE WALL.** Then pull the unit out by the unplugged cords.

In Case Of Difficulty

If you have difficulty operating your phone, the suggestions below should solve the problem. If you still have difficulty after trying these suggestions, call Vtech Communications at 1-800-595-9511. In Canada, call VTECH Electronics at 1-800-267-7377.

The Phone Doesn't Work At All

- Make sure the Handset Security Code is properly loaded into the Base Unit.
- Make sure the Power Cord is plugged into the Base and Handset Chargers.
- Make sure the telephone line cord(s) is plugged firmly into the Base Unit and the telephone wall jack.
- Make sure the batteries are properly charged. If the low battery indicator is shown, the battery pack needs charging.

No Dial Tone

- First check all the suggestions above.
- If you still don't hear a dial tone, disconnect the Base Unit from the telephone jack(s) and connect a different phone. If there is no dial tone on that phone either, the problem is in your wiring or local service. Contact your local telephone company.

You Get Noise, Static, Or A Weak Signal Even When You're Near The Base Unit

- Household appliances plugged into the same circuit as the Base Unit can sometimes cause interference. Try moving the appliance or the Base Unit to another outlet.

You Get Noise, Static, Or A Weak Signal When You're Away From The Base Unit

- You may be out of range. Either move closer to the Base, or relocate the Base Unit.
- The layout of your home or office may be limiting the range. Try moving the Base Unit to another position.
- Make sure the Base Unit Antenna is rotated up.

In Case Of Difficulty

The Handset Does Not Ring When You Receive A Call

- Make sure you have the Handset ringer activated. To set the ringer, see **RINGER CONTROL**.
- Make sure the telephone line cord(s) is plugged firmly into the Base Unit and the telephone jack(s). Make sure the power cord is plugged in.
- You may be too far from the Base Unit.
- You may have too many extension phones on your telephone line to allow all of them to ring. Try unplugging some of the other phones.

You Hear Other Calls While Using Your Phone

- Disconnect your Base Unit from the telephone jack(s), and plug in a regular telephone. If you still hear other calls, the problem is probably in your wiring or local service. Call your local telephone company.

You Hear Noise In The Handset, And None Of The Keys Or Buttons Work

- Make sure the power cord is plugged into the Base Unit.

Common Cure For Electronic Equipment

If the unit does not seem to be responding normally, then try putting the Handset in the cradle. If it does not seem to respond, do the following (in the order listed):

1. Disconnect the power to the Base.
2. Disconnect the Handset battery.
3. Wait a few minutes.
4. Connect power to the Base.
5. Re-install the battery pack (s)
6. Check for dial tone.

Warranty

WHAT DOES OUR WARRANTY COVER?

- Any defect in material or workmanship.

FOR HOW LONG AFTER THE ORIGINAL PURCHASE?

- To the original purchaser only - ONE YEAR.

WHAT WILL VTECH DO?

- At our option, repair or replace your unit.

HOW DO I SEND MY UNIT, IN OR OUT OF WARRANTY?

- In the U.S. Call Vtech Communications Inc customer service for Return Authorization at: 1-800-595-9511. In Canada, call Vtech Electronics Ltd at 1-800-267-7377
- Properly pack your unit. Include any cables & accessories which were originally provided with the product. We recommend using the original carton and packing materials.
- Include in the package a copy of the sales receipt or other evidence of date of original purchase (if the unit was purchased within the last twelve months).
- Print your name and address, along with a description of the defect, and include this in the package.
- Include payment for any service or repair not covered by warranty, as determined by VTech Communications Ltd.
- Ship the unit via UPS Insured, or equivalent to:
In the U.S.

VTECH COMMUNICATIONS INC.

1145 Coliseum Rd. Dept. Vtech
San Antonio, TX. 78219

If you purchased your phone in Canada, Ship the unit via UPS insured, or equivalent to:

VTECH ELECTRONICS LTD.

SUITE 200-7671 ALDERBRIDGE WAY
RICHMOND, B.C. V6X 1Z9

VTech Communications Inc assumes no responsibility for units sent without prior Return Authorization.

Warranty

WHAT DOES OUR WARRANTY NOT COVER?

- Batteries
- Damage from misuse, neglect, or acts of nature (lightning, floods, power surges, etc.)
- Products which may have been modified or incorporated into other products
- Products purchased and/or operated outside the USA, its territories, or Canada.
- Products serviced by the owner or a service facility not expressly authorized by VTECH Communications
- Products purchased more than 12 months from current date
- Units purchased in "AS IS" condition, or units purchased as "Distressed Merchandise".

HOW DOES STATE LAW OR PROVINCIAL LAW RELATE TO THIS WARRANTY?

- This warranty gives you specific rights. You may also have other rights which vary from state to state or province to province.

Technical Specifications

FREQUENCY CONTROL

Crystal controlled PLL synthesizer

TRANSMIT FREQUENCY

2402.3040 - 2481.1520 MHz

RECEIVE FREQUENCY

2402.3040 - 2481.1520 MHz

CHANNELS

73 Channels

NOMINAL EFFECTIVE RANGE

Maximum power allowed by FCC and IC. Actual operating range may vary according to environmental conditions at the time of use.

SIZE

Handset : 57mm x 41mm x 200mm

Base : 229mm x 515mm x 165mm

Charger: 113mm x 63mm x 78mm

WEIGHT

Handset : 234 grams

Base : 524 grams

Charger: 102 grams

POWER REQUIREMENTS

Handset : 3.6 VDC NiMH Battery Pack

Base : 9 V 1000mA

Charger: 9 V 500mA

MEMORY

Speed Dial: 20 Memory locations - Name Field: 16 characters (max.), Number Field: 30 digits (max.)

CID : Alpha Numeric Display 50 Memory locations

SPECIFICATIONS ARE TYPICAL AND MAY CHANGE WITHOUT NOTICE.

This equipment complies with Parts 15 of the Federal Communications Commission (FCC) rules for the United States. It also complies with regulations RSS210 and CS-03 of Industry and Science Canada. Operation is subject to the following two conditions: (1) this device may not cause interference, and (2) this device must accept any interference, including interference that may cause undesired operation of the device.

A label is located on the underside of the Base Unit containing either the FCC registration number and Ringer Equivalence Number (REN) or the IC registration number and Load Number. You must, upon request, provide this information to your local telephone company.

This equipment is compatible with inductively coupled hearing aids.

Should you experience trouble with this telephone equipment, please contact:

Vtech Communication Inc

SERVICE DEPT. at 1-800-595-9511.

In Canada, call VTECH Electronics at 1-800-267-7377.

For repair / warranty information. The telephone company may ask you to disconnect this equipment from the line network until the problem has been corrected.

FCC Part 15

Warning: Changes or modifications to this unit not expressly approved by the party responsible for compliance could void the user's authority to operate the equipment.

The equipment has been tested and found to comply with part 15 of the FCC rules. These limits are designed to provide reasonable protection against harmful interference in a residential installation. This equipment generates, uses and can radiate radio frequency energy and, if not installed and used in accordance with the instructions, may cause harmful interference to radio communications.

However, there is no guarantee that interference will not occur in a particular installation. If this equipment does cause harmful interference to radio or television reception, which can be determined by turning the equipment off and on, the user is encouraged to try and correct the interference by one or more of the following measures:

- Reorient or relocate the receiving antenna.
- Increase the separation between the equipment and receiver.
- Connect the equipment into an outlet or on a circuit different from that which the receiver is connected.
- Consult the dealer or an experienced radio/TV technician for help.

FCC Part 68

The FCC requires that you connect your cordless telephone to the nationwide telephone network through a modular telephone jack (USOC RJ11C, RJ11W or RJ14).

Your telephone company may discontinue your service if your equipment causes harm to the telephone network. They will notify you in advance of disconnection, if possible. During notification, you will be informed of your right to file a complaint with the FCC.

Occasionally, your telephone company may make changes in its facilities, equipment, operation, or procedures that could affect the operation of your equipment. If so, you will be given advance notice of the change to give you an opportunity to maintain uninterrupted service. The Base Unit contains no user serviceable parts. The Handset contains a user replaceable battery pack.

If it is determined that your telephone equipment is malfunctioning, the FCC requires that it not be used and that it be unplugged from the modular jack until the problem has been corrected. Repairs to this telephone equipment can only be made by the manufacturer or its authorized agents, or by others who may be authorized by the FCC. For repair procedures, follow the instructions outlined under the VTECH Limited Warranty.

This equipment may not be used on coin service provided by the phone company or Party Lines.

The REN is useful in determining the number of devices you may connect to your telephone line and still enable the devices to ring when you receive a call. The general rule is that the REN value should not exceed 5.0A total; however, contact your local telephone company for the specific number in your area.

IC (Industry Canada)

This telephone is registered for use in Canada.

Notice:

The REN assigned to this device denotes the number of devices you may connect to the telephone loop which is used by the device to prevent overloading. The termination on a loop may consist of any combination of devices subjected only to the requirement that the sum of the REN does not exceed five (5.0)

Notice:

The Industry Canada label identifies certified equipment. This certification means that the equipment meets certain telecommunications network protective, operational and safety requirements. The Department does not guarantee the equipment will operate to the user's satisfaction.

vtech

VTECH TELECOMMUNICATIONS LTD.



A member of THE VTECH GROUP OF COMPANIES.

Distributed in the U.S.A. by VTech Communications Inc, 1145 Coliseum Rd. Dept. Vtech
San Antonio, TX. 78219

Distributed in Canada by VTech Electronics Canada Ltd., Suite 200-7671 Alderbridge Way
Richmond, B.C. V6X 1Z9.

Copyright 2001 for VTECH TELECOMMUNICATIONS LTD.

Printed in China

vtech

SPREAD
SPECTRUM
DIGITAL

24MHz

40-2420
40-2421
MULTI-HANDSET OPERATION

USER'S MANUAL



vtech

VTECH TELECOMMUNICATIONS LTD.
www.vtechphones.com